

KOKOAMISOHJEET

VEKE:LUDVIKA TUOLI

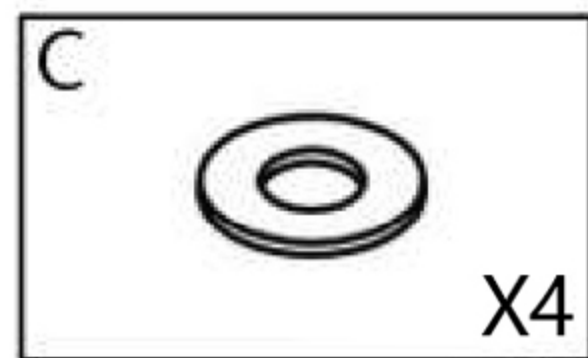

1

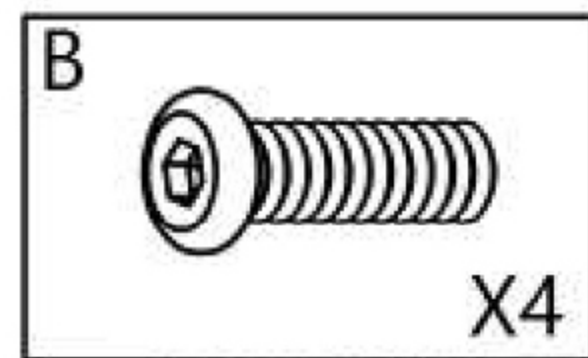
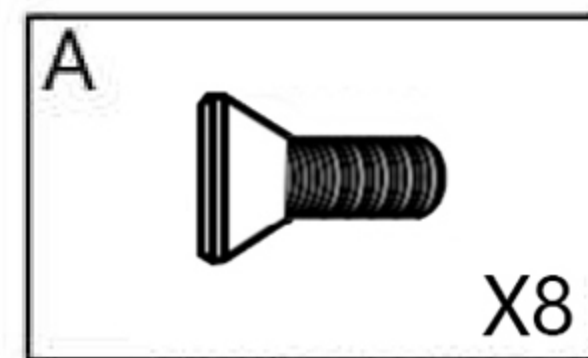
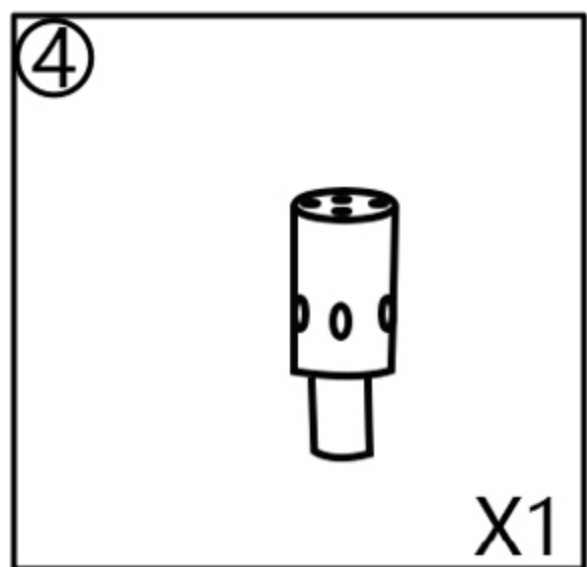
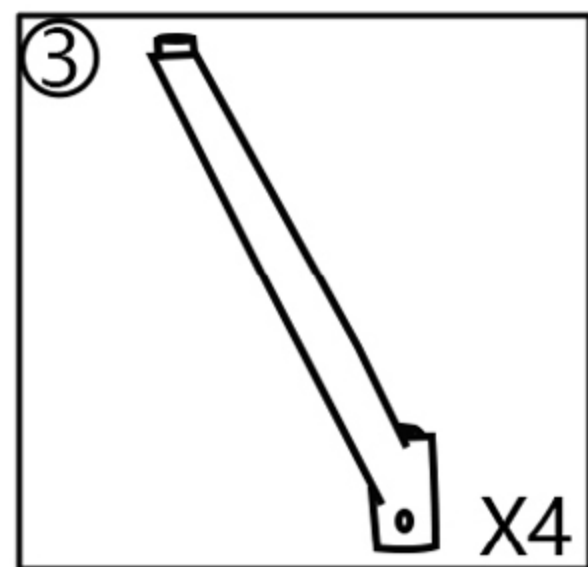
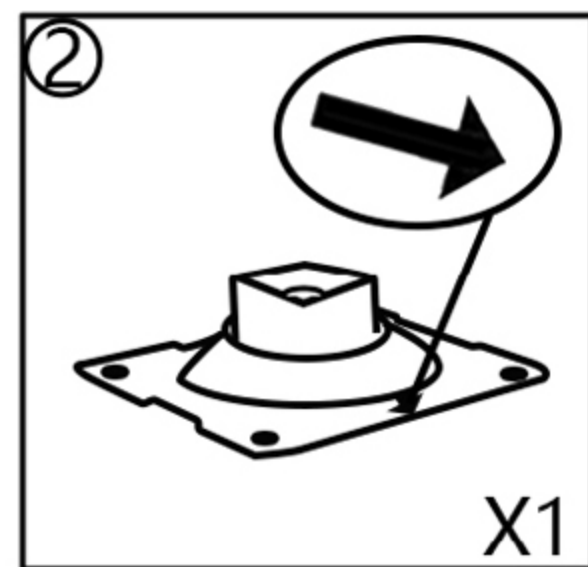
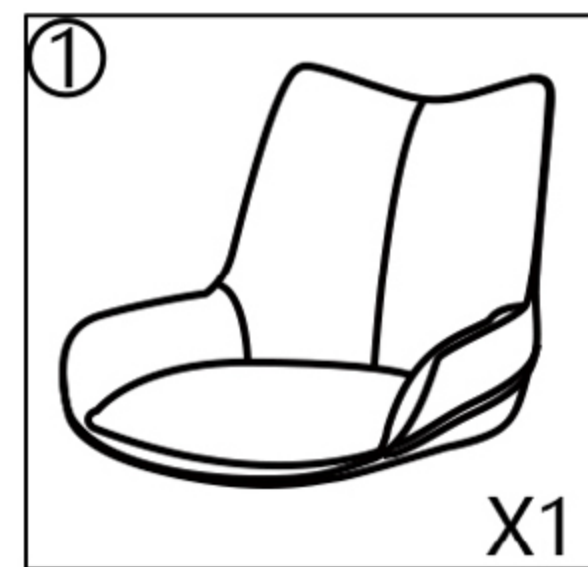
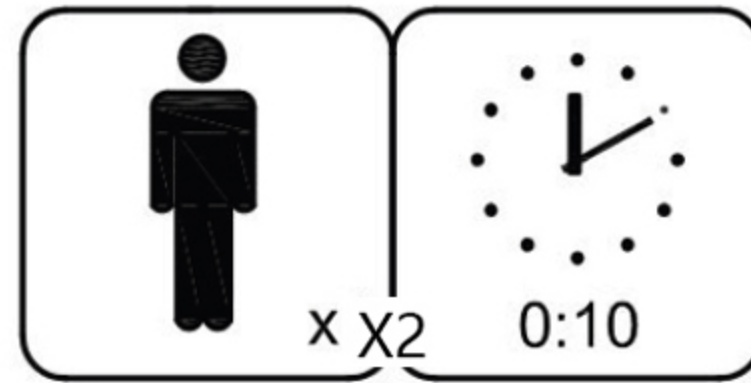
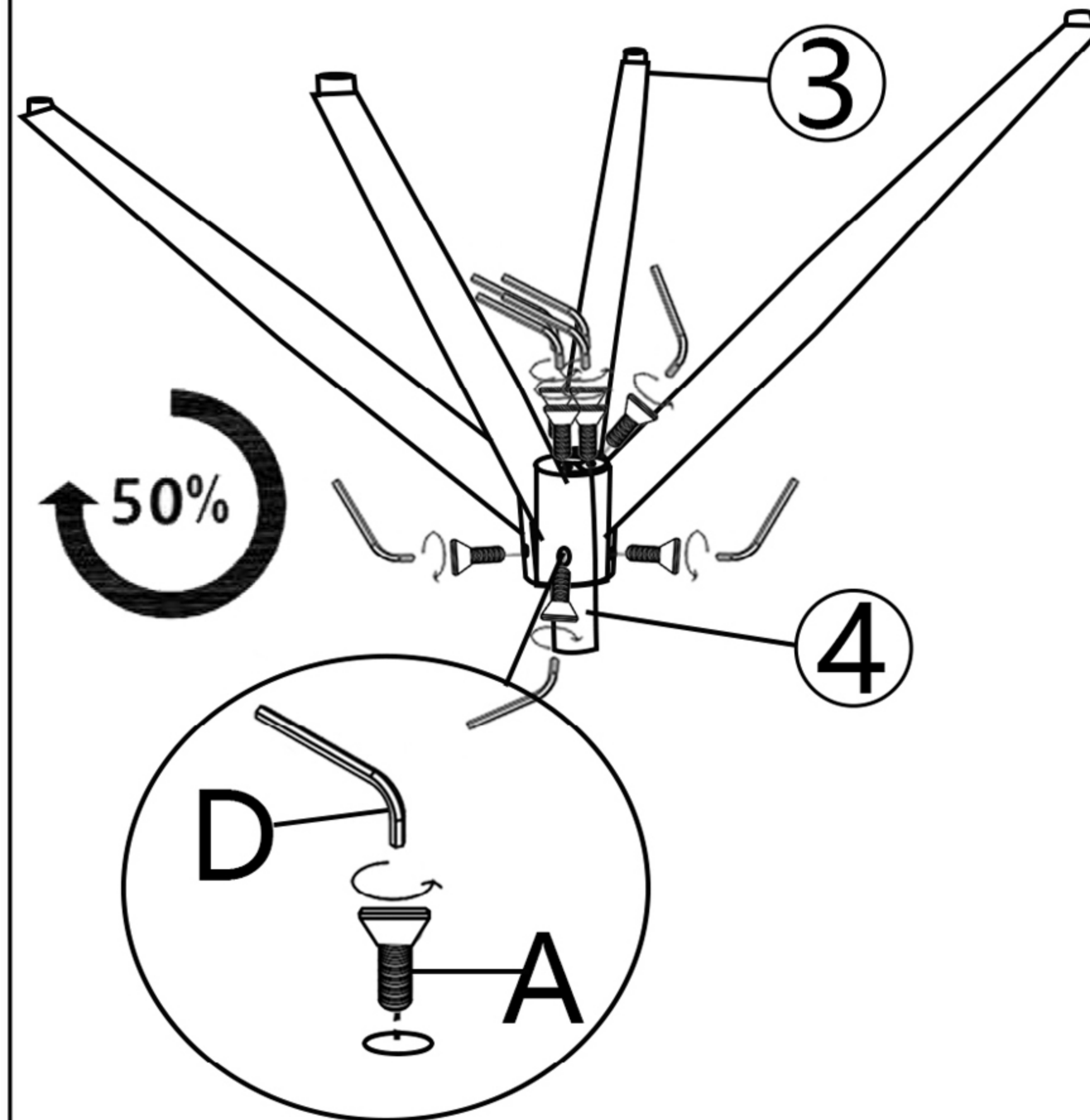

2

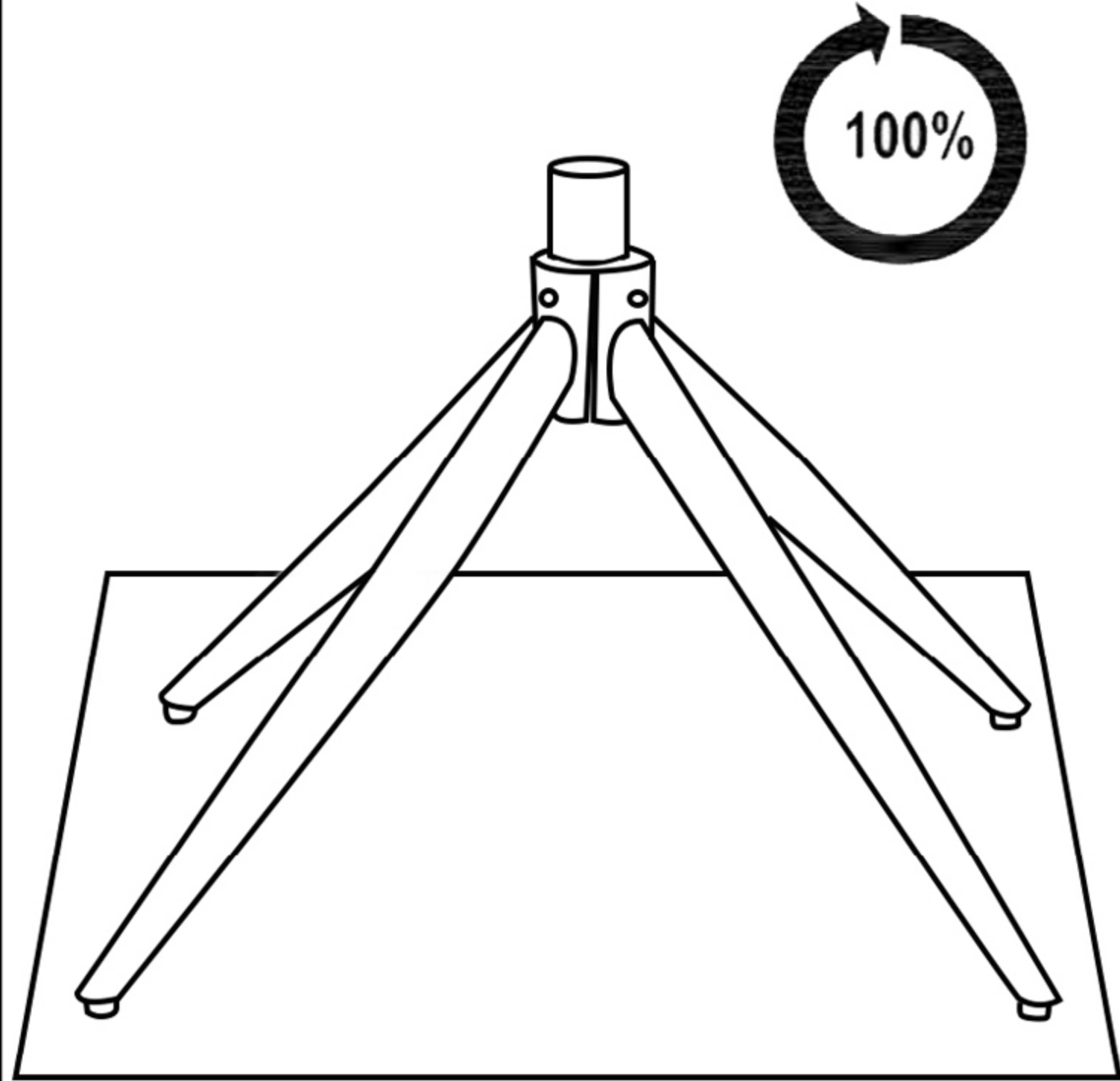

3

→ ASETA LEVY
KESKELLE JA
SUORAKSI.

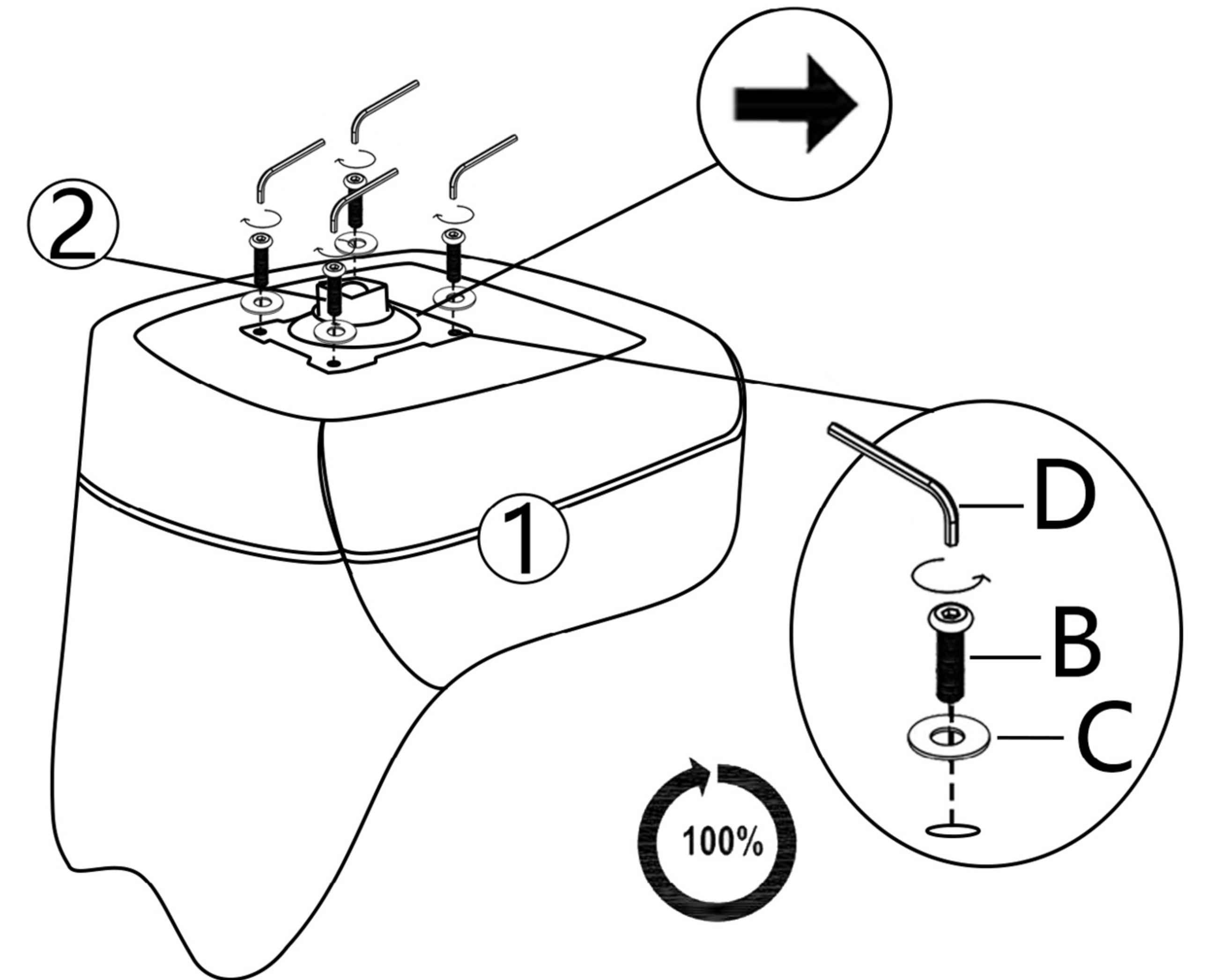

4

→ KOHDISTA AINOASTAAN
PYÖRIVÄN AKSELIN
ASENNUSREIKÄ. ÄLÄ
PAINA OSAA TÄSSÄ
VAIHEESSA!

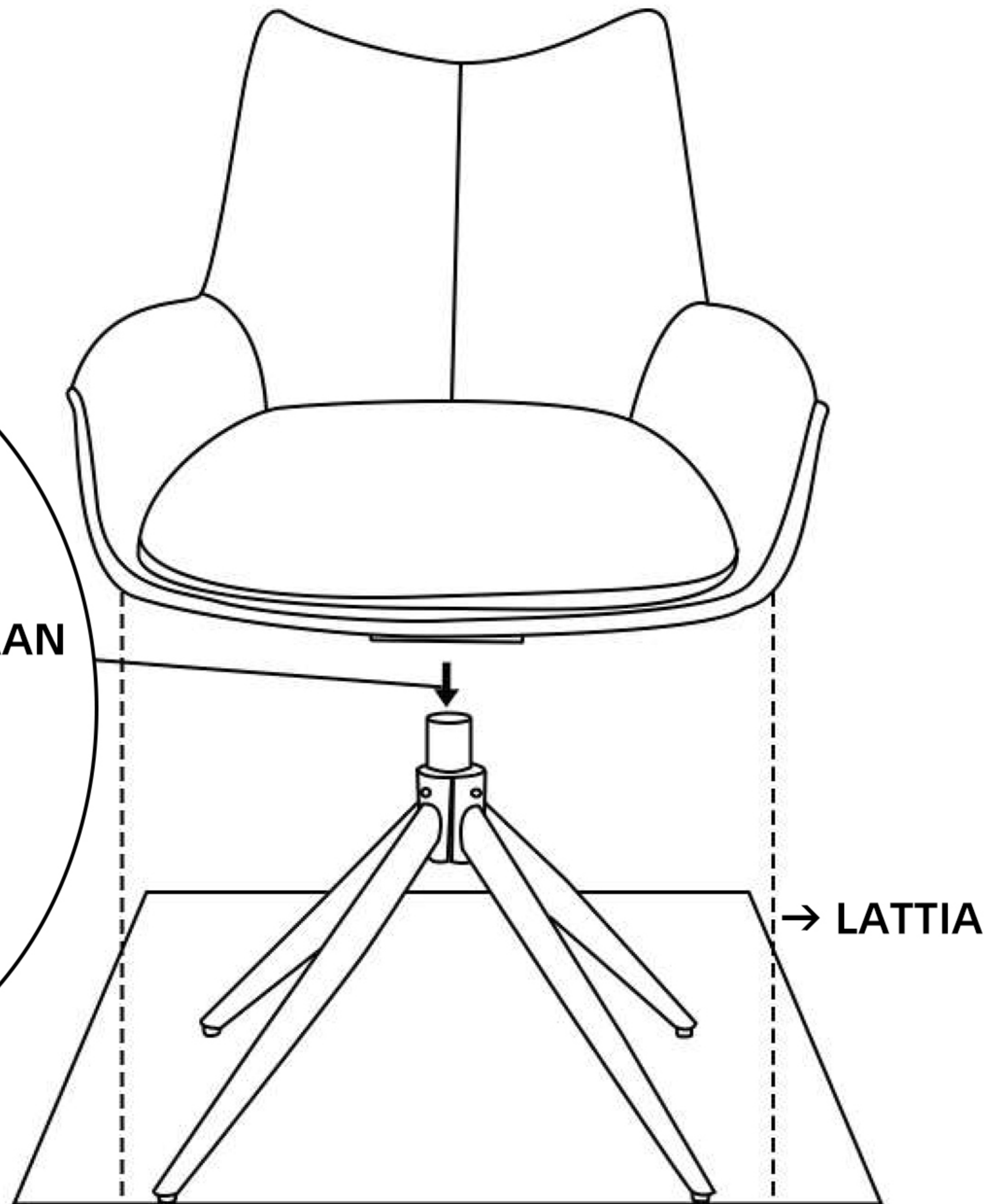

→ PIDÄ ISTUIN JA JALKA SAMASSA
ETUASENNOSSA.

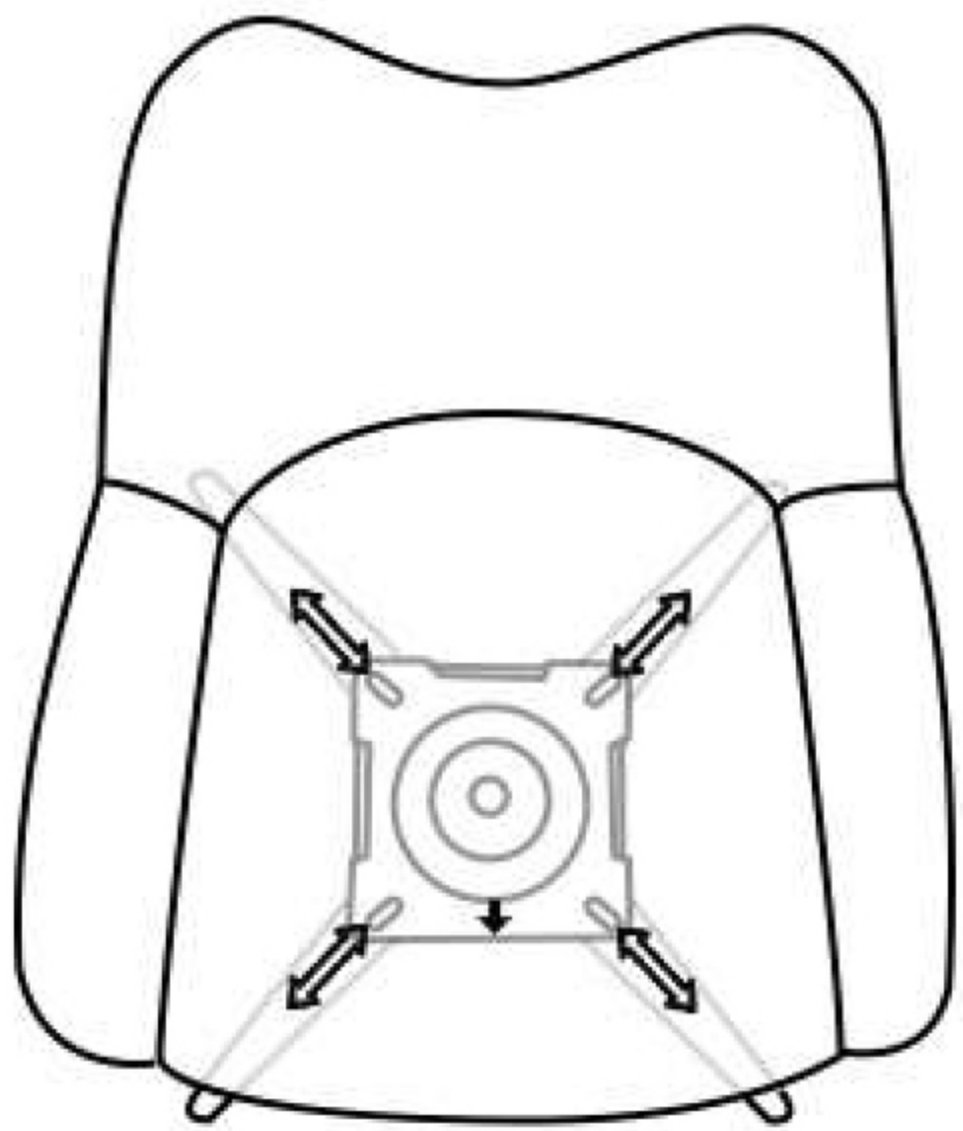

5

→ PIDÄ ISTUIN JA JALKA
SAMALLA ETUTASOLLA. JOS
ASENTO EI OLE OIKEA, VOIT
HELPOSTI IRROTTAA
ISTUIMEN SÄÄTÖÄ VARTEN.

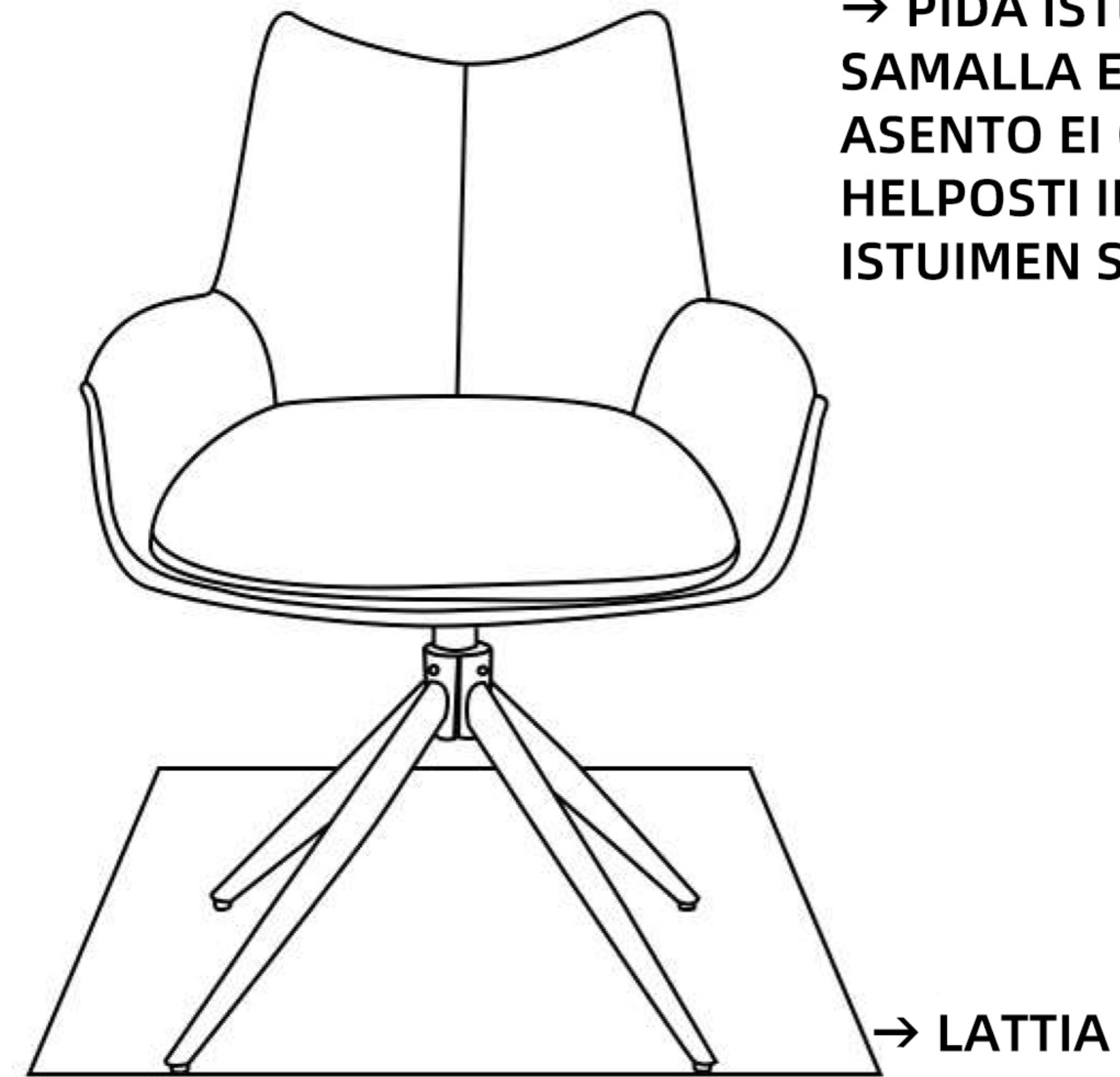

6

→ PAINA OSA TIUKASTI
PAIKALLEEN.

